



# Electric Doughnut Fryers

Friggitrici elettriche per ciambelle



Standard 3Ph - 50/60Hz  
On request 220V - 1Ph - 50/60Hz

mac.pan



FRY / M



FRY / S



FRY / A

Our machines are designed, manufactured and assembled in ITALY. - Le nostre macchine sono progettate, costruite e assemblate in ITALIA.



## FRY / M (MANUAL VERSION)

Manual machines are used for baking donuts. They are made of stainless steel. Version with and without chamber for fermentation. Performance without fermentation chamber we called tabletop fryers. Tub oil volume 26 or 36 liters. Frying capacity 16 or 24 pcs per time, hourly frying capacity 160 or 240 pcs/h. Analogic control panel.

Friggitrici manuali per donuts. Realizzate interamente in acciaio inossidabile. Versione con e senza camera di fermentazione (modello da banco). Quantità olio in vasca 26 o 36 litri. Capacità cottura vasca di 16 o 24 pezzi per volta, produzione oraria 160 o 240 pezzi / h. Pannello di controllo analogico.

## FRY / S (SEMI-AUTOMATIC VERSION)

Semiautomatic machines are used for baking donuts. They are made of stainless steel. Version with and without chamber for fermentation. Simple operation, baking quality, effective and fast operation, small energy loss. Long service life. Tub oil volume 43 or 55 or 67 liters. Frying capacity 36 or 48 or 60 pcs per time, hourly frying capacity 360 or 480 or 600 pcs/h. Digital control panel.

Friggitrici semiautomatiche per donuts. Realizzate interamente in acciaio inossidabile. Versione con e senza camera di fermentazione. Quantità olio in vasca 43 o 55 o 67 litri. Capacità cottura vasca di 36 o 48 o 60 pezzi per volta, produzione oraria 360 o 480 o 600 pezzi / h. Pannello di controllo digitale.

## FRY / A (AUTOMATIC VERSION)

Automatic machine used for automatic baking donuts. Made of stainless steel. Version with and without chamber for fermentation. Simple operation, baking quality, effective and fast operation, small energy loss. Long service life. Tub oil volume 67 liters. Frying capacity 60 pcs per time, hourly frying capacity 600 pcs/h. Touch-screen control panel.

Friggitrici automatiche per donuts. Realizzate interamente in acciaio inossidabile. Versione con e senza camera di fermentazione. Quantità olio in vasca 67 litri. Capacità cottura vasca di 60 pezzi per volta, produzione oraria di 600 pezzi/h. Pannello comandi touch-screen.

descrizione • description

As continued product improvement is a policy of MAC.PAN Srl, specifications are subject to change without notice.

MODEL	version (M/S/A)	tub oil volume lt	frying capacity pcs	hourly frying capacity pcs/h	bench type			with proofer	power kW	voltage V-Hz	dimensions mm				weight Kg
					B	S	C				A	B	C	D	
FRY16MB	MANUAL	26	16	160	✓	X	X		3	230-50	687	210	645	1174	50
FRY16MS	MANUAL	26	16	160	X	✓	X		3	230-50	687	1080	645	1174	60
FRY16MC	MANUAL	26	16	160	X	X	✓		3	230-50	687	1080	645	1174	70
FRY24MB	MANUAL	36	26	240	✓	X	X		3,6	400-50	880	210	645	1560	60
FRY24MS	MANUAL	36	26	240	X	✓	X		3,6	400-50	880	1080	645	1560	75
FRY24MC	MANUAL	36	26	240	X	X	✓		3,6	400-50	880	1080	645	1560	85
FRY36SS	SEMI-AUTO	43	36	360	X	✓	X		7,4	400-50	860	1075	820	1560	105
FRY36SC	SEMI-AUTO	43	36	360	X	X	✓		8,6	400-50	860	1075	820	1560	130
FRY48SS	SEMI-AUTO	55	48	480	X	✓	X		7,4	400-50	1050	1075	820	1942	150
FRY48SC	SEMI-AUTO	55	48	480	X	X	✓		8,6	400-50	1050	1075	820	1942	175
FRY60SS	SEMI-AUTO	67	60	600	X	✓	X		7,4	400-50	1243	1075	820	2315	195
FRY60SC	SEMI-AUTO	67	60	600	X	X	✓		8,6	400-50	1243	1075	820	2315	220
FRY60AS	AUTOMATIC	67	60	600	X	✓	X		7,4	400-50	1400	1075	820	2500	195
FRY60AC	AUTOMATIC	67	60	600	X	X	✓		8,6	400-50	1400	1075	820	2500	220

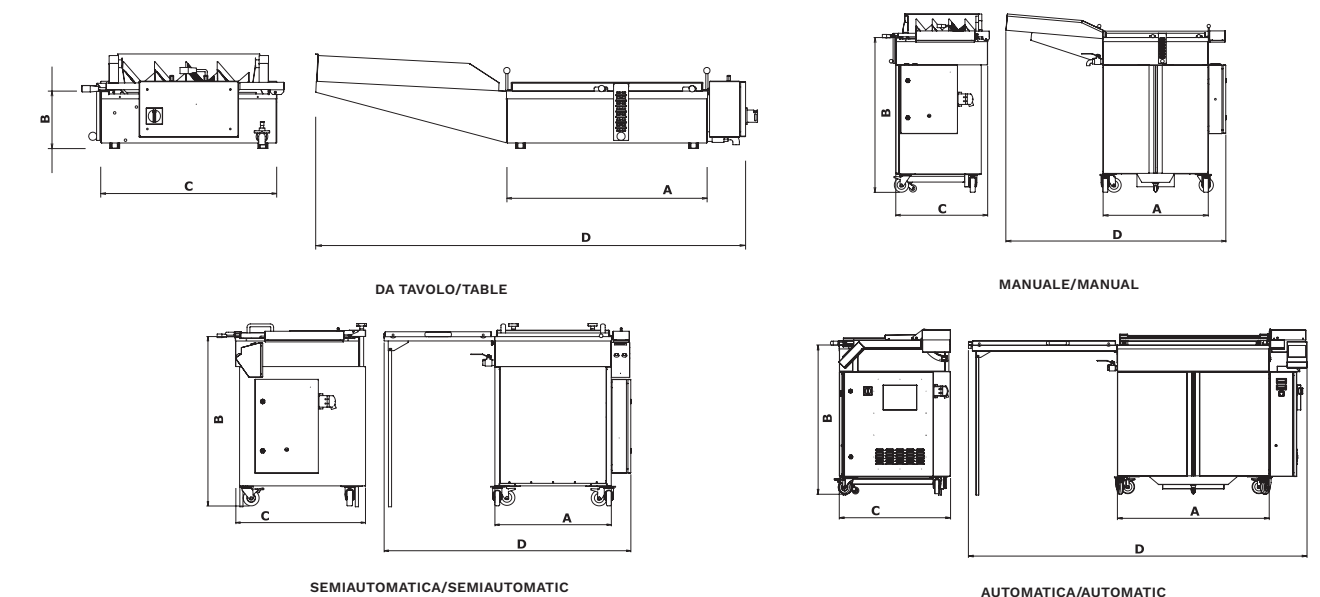

SINCE 1983